

## Fig. 30E

- Válvula Esfera
- Cuerpo de 3 piezas · Paso completo
- Acero al carbón WCB e Inoxidable tipo 316
- 1000 WOG · Base ISO

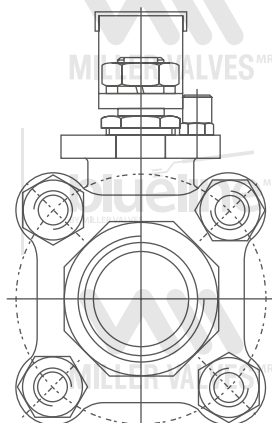
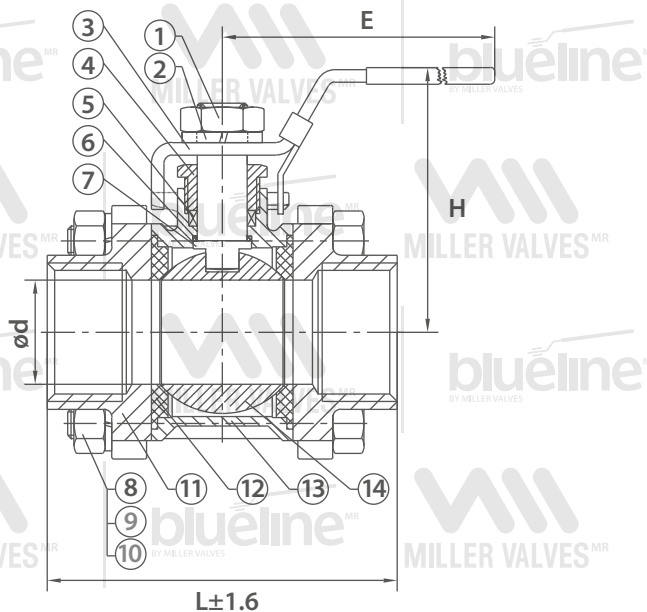
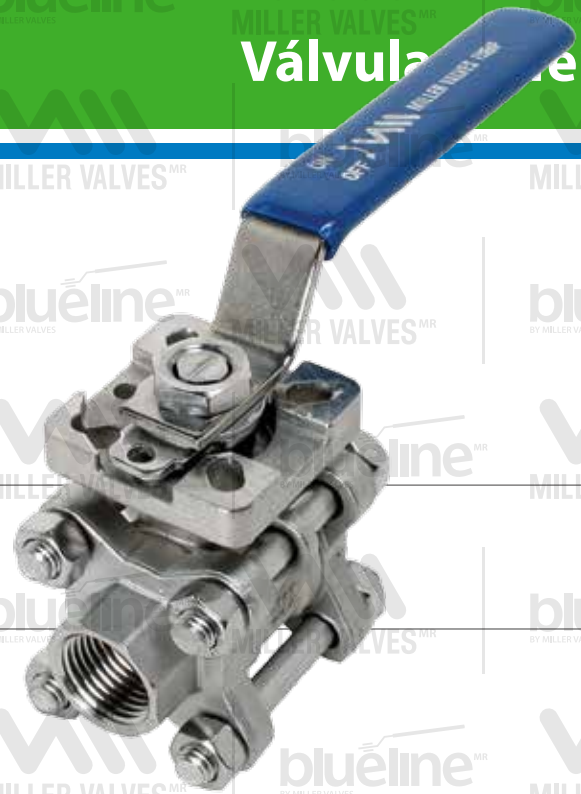

MATERIALES		
No.	Parte	Material
1	Tuerca	304
2	Arandela de resorte	304
3	Mango	201
4	Tuerca de casquillo	304
5	Embalaje	PTFE
6	Arandela de empuje	PTFE
7	Vástago	304/316
8	Perno	304
9	Arandela de resorte	304
10	Tuerca	304
11	Casquete	WCB/CF8/CF8M
12	Asiento	PTFE
13	Caja	WCB/CF8/CF8M
14	Bola	304/316

DIMENSIONES											
	1/4"	3/8"	1/2"	3/4"	1"	1 1/4"	1 1/2"	2"	2 1/2"	3"	4"
ød	8	10	15	20	25	32	38	49	65	80	100
H	45	45	55	65	70	80	90	100	125	135	180
L	62	62	75	80	90	110	120	140	166	197	253
E	95	95	105	115	125	145	165	170	215	250	315

PARÁMETRO TÉCNICO PRINCIPAL		
Presión nominal		1000PSI
Presión de prueba	Prueba de fugas de carcasa	10.4
	Cierre de alta presión	7.6
	Cierre de baja presión	0.4~0.7
Temperatura aplicable		-29~180°C
Medio aplicable: Agua, aceite y gas.		